

Dust & Water-Proof Precision Balances

FZ-iWP **FX-iWP**

Series



FZ-iWP



FX-iWP



AND ...Clearly a Better Value
A&D Company, Limited
<http://www.aandd.jp>

The World's First IP65 Compliant, Dust & Water-Proof Precision (1 mg) Balances

Yet another breakthrough from A&D enabling the measurement of powder or liquid at 1 mg resolution, eliminating any worries about damage to the balance!

What does "IP65" mean?

An International Protection (IP) Code, as defined by the international standard IEC 60529, specifies the degrees of protection provided by enclosures. The two digits next to IP indicate the levels of protection against solid foreign objects (first digit) and water (second digit). For example, a device rated as IP65 should permit no ingress of dust (level 6) and withstand water jetting from any direction (level 5).



Newly Developed, Air-Pump Controlled Internal Calibrationⁱ (FZ-iWP models only) *ⁱ Patent Pending

For the internal calibration of the FZ-iWP Series, A&D adopted a direct-driving method that utilizes air pressure for its power source. This new method features a simple structure, high reliability and a fail-safe mechanism – the internal mass returns to the original position even if the calibration is interrupted by power failure, etc.

One Touch Automatic Calibration (FZ-iWP models only)

With just one press of a key, you can ensure the accuracy of your balance.



(FZ-iWP)

(FX-iWP)

Compact, B5 Size Footprint

A&D's latest, Compact Super Hybrid Sensor (C-SHS) technologyⁱⁱ has significantly reduced the size of the FZ-iWP/FX-iWP Series – a 25% smaller footprint than the GX/GF Series – making it ideal for installation and use in narrow spaces. *ii Patent Pending

Fast, 1 Second Stabilization

While maintaining extremely high span stability, the C-SHS also realizes an ultra-fast response speed – just 1 second – to maximize your productivity and efficiency.

RS-232C Interface (standard)

Bi-directional communication is possible with a PC, printer or other peripheral device.



Dust & Water-Proof RS-232C Cable (optional)

Quick USB Interface (FXi-02)

The easy-to-use optional USB interface requires no driver or software installation for transfer of weighing data to a PC.ⁱⁱⁱ

LAN-Ethernet Interface (FXi-08) with WinCT-Plus Software

The user can send commands for controlling and acquiring data from multiple balances.



*iii Unidirectional communication from a balance to a PC only. Please use the standard RS-232C interface to send commands from a PC to the balance.

Shock Absorber Function^{iv}

The internal shock absorber protects the C-SHS from the adverse effects of vertical and transverse overloading. *iv Patent Pending

Multiple Weighing Units

Programmable or standard weighing units of measurement can be selected: g, pcs, %, oz, lb, L oz, ozt, ct, mom, dwt, GN, tl, tol, mes, and MLT.

Statistical Calculation Function

The balance displays and/or outputs statistical calculation data as No. (number of data), SUM (total), MAX (maximum), MIN (minimum), R [range (maximum – minimum)], AVE (average), SD (standard deviation) and CV (coefficient of variation).

Built-in Rechargeable Battery (FXi-09)

An optional Ni-MH rechargeable battery pack can be fitted into the balance for use without AC power and for mobile applications (10 hours charging time for 8 hours operation).

Large Breeze Break (FXi-WP-11)

Note:
All FZ-iWP models, the FX-120iWP, the FX-200iWP and the FX-300iWP come with a small breeze break as standard.



Specifications

	FZ-120iWP FX-120iWP	FZ-200iWP FX-200iWP	FZ-300iWP FX-300iWP	FZ-1200iWP FX-1200iWP	FZ-2000iWP FX-2000iWP	FZ-3000iWP FX-3000iWP
Weighing capacity	122g	220g	320g	1220g	2200g	3200g
Minimum weighing value	0.001g			0.01g		
Counting mode	Minimum unit mass 0.001g			0.01g		
	Number of samples			5, 10, 25, 50 or 100 pieces		
Percent mode	Minimum 100% reference mass 0.100g			1.00g		
	Minimum 100% display			0.01%, 0.1%, 1% (depends on the reference mass stored)		
Repeatability (Standard Deviation)	0.001g			0.01g		
Linearity	±0.002g			±0.02g		
Stabilization time (typically set at FAST)	Approx. 1 second					
Sensitivity drift (10°C to 30°C)	±2ppm / °C					
Operating temperature	5°C to 40°C (41°F to 104°F), 85%RH or less (no condensation)					
Display type	Vacuum Fluorescent Display (VFD)					
Display refresh rate	5 times /second, 10 times /second or 20 times /second					
Standard interface	RS-232C Interface					
Weighing pan (diameter)	130mm			150mm		
Internal calibration	Air-pump Controlled Internal Calibration (FZ-iWP models only)					
External calibration mass	100g 50g	200g 100g	300g 200g 100g	1000g 500g	2000g 1000g	3000g 2000g 1000g
AC adaptor	Confirm that the adaptor type is correct for the local voltage and power receptacle					
Power consumption	Approx. 11VA (supplied to the AC adaptor)					
External dimensions	193 (W) X 262.5 (D) X 85.5 (H) mm					
Net weight	FZ-iWP Approx. 3.2kg / FX-iWP Approx. 2.7kg					

Options

- FXi-02*** Quick USB interface with cable
- FXi-08*** Ethernet interface with WinCT-Plus software
- FXi-09*** Built-in rechargeable battery
- FXi-WP-10** Small breeze break (gray)
- FXi-WP-11** Large breeze break (gray)
- FXi-12** Animal weighing pan
- FXi-15** Carrying case

* FXi-02, FXi-08 and FXi-09 cannot be used at the same time
(Not IP65 compliant when used with FZ,FX-iWP)

Accessories

- AD-1683** Static eliminator
- AD-1684** Electrostatic fieldmeter
- AD-1688*** Weighing data logger
- AD-1689** Tweezers for calibration weight
- AD-8920A*** Remote display
- AD-8922*** Remote controller
- AD-8121B*** Compact printer
- AD-8118C*** Universal printer
- AD-8526*** Serial/Ethernet converter
- AD-8527*** Quick USB adapter
- AX-USB-9P*** Serial/USB converter
- AX-KO2737-500-EX** Waterproof RS-232C cable (5m)
- AX-CARATPAN-W** Carat pan (silver, 2pcs)
- AX-CARATPAN-B** Carat pan (black, 2pcs)
- AX-FXi-31** Main unit cover (5pcs)

* (Not IP65 compliant when used with FZ,FX-iWP)



FXi-12

External Dimensions (mm/inches)

Pan size

Model	A
FZ,FX-120iWP / 200iWP / 300iWP	130 / 5.12
FZ,FX-1200iWP / 2000iWP / 3000iWP	150 / 5.91

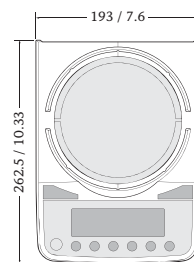
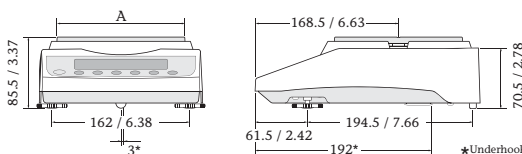

Dimensions with Small Breeze Break (FXi-WP-10)

(Comes equipped with FZ,FX-120iWP/200iWP/300iWP, FZ-1200iWP/2000iWP/3000iWP)

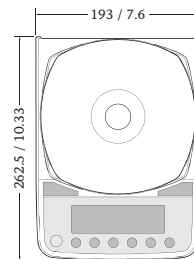
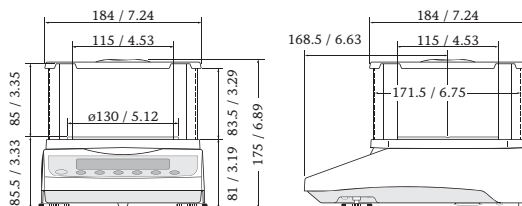

Dimensions with Large Breeze Break (FXi-WP-11)

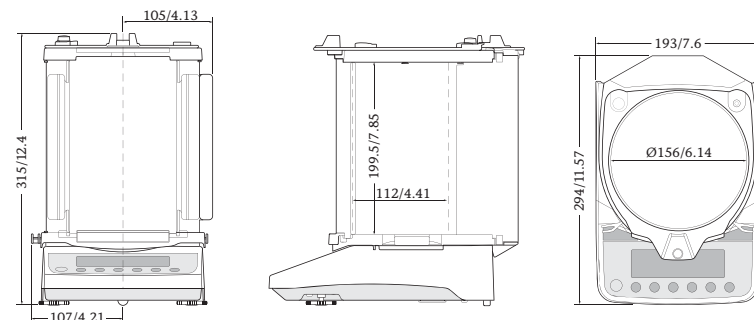

AND

...Clearly a Better Value



GAMMA SCALE™

Weighing Instruments

Sales & Service

Tel: (905)455-8333

Fax: (905)455-0658

E-mail: info@gammascale.com

Website: www.gammascale.com