

TOSHIBA



AC-4000

SERIES

From simple price computing to multi-store data management solutions, the AC-4000 series will streamline your entire retail operation.

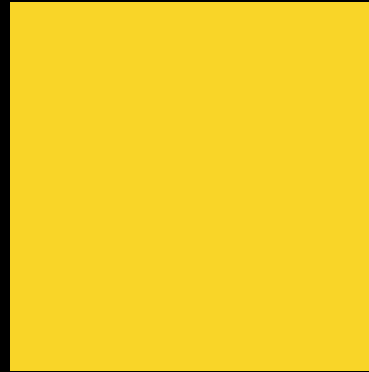

AC-4000H



Shown with optional mounting hardware

A hanging scale for special applications

- Ideal for seafood and produce
- Two pan styles provided:
solid and perforated for drainage
- Features a stainless steel enclosure designed
for easy cleaning
- Perfect for tight areas with limited counter space
- Dual-sided display (optional)

AC-4000D

A prepack scale that stands up to your toughest work loads

- Realize increased productivity
with large 230 mm (9 inches) label rolls
- Modular components work with
any handwrap station
- Flexible setup for ergonomic operation
- Stainless steel enclosure suitable
for USDA applications



Shown with optional prepack equipment

Harness the power and flexibility of the AC-4000 series to maximize efficiency and profitability



AC-4000 Series

- Ethernet connectivity for on-line data management
- Simple, user-friendly operation
- Security with operator log on/off and access levels
- Ishida's proven durability and reliability
- Prints patented coupon labels or itemized receipts

AC-4000/B/E

Countertop scales with flexible labeling have never been so powerful

- Fast printing speed results in greater customer output
- Multiple label formats for multi-department support
- Powerful batch printing feature frees operator's time
- Up to 186 (184 for USA) function keys assist with intuitive operation (PLU, Tare, Price, Multiple, Special price, \$ discount, % discount, Void, Extra Message, Proportional Tare and more)
- Bright dot matrix display for messaging
- To suit your application needs the AC-4000 cassette model offers quick label changes while the AC-4000E model's simply features weight and pricing displays



Label as AC-4000



AC-4000E

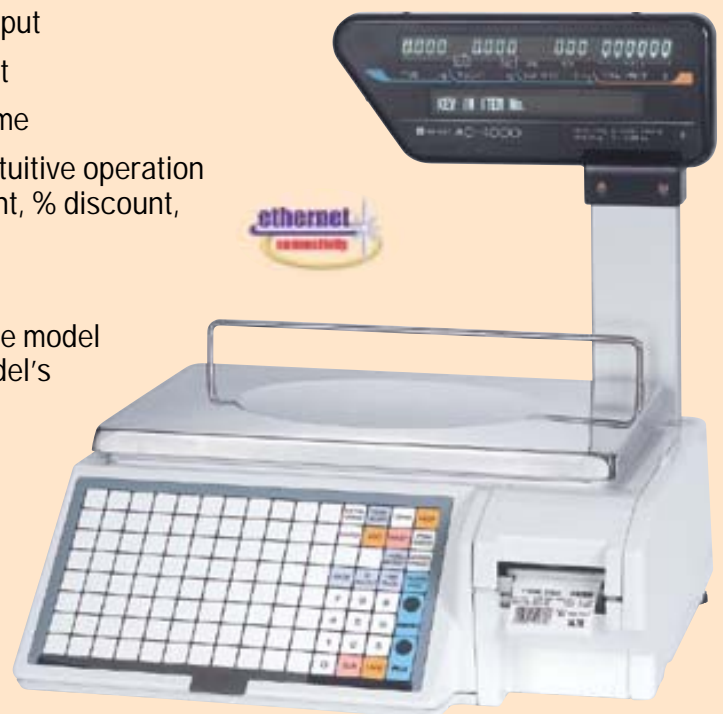

AC-4000B



Streamline data management with ScaleLink Pro Software

ScaleLink Pro is a powerful Windows-based program that integrates new or existing computer networks using a PC server or a multi-store centralized host. The point-and-click menus mean you're able to make price changes immediately or create sale batches, centrally or in store. Distribution can be immediate or scheduled to all scales. You can create reports showing production totals by operator, hourly, daily, or weekly. With ScaleLink Pro you'll be assured that what is coming in the back door is getting to the scale, and into the register.

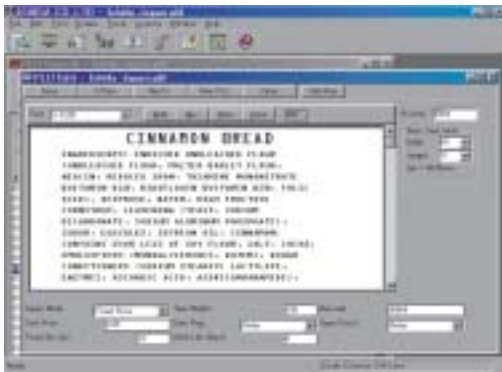

PLU Edit Screen



Keysheet

Ethernet allows seamless system integration

Whether communication originates from an in-store PC or a headquarters host system, the AC-4000 series is designed to support all your data management needs. The AC-4000 series offers a storewide on-line system with full Ethernet (TCP/IP) support for ScaleLink Pro and third-party scale management software programs.

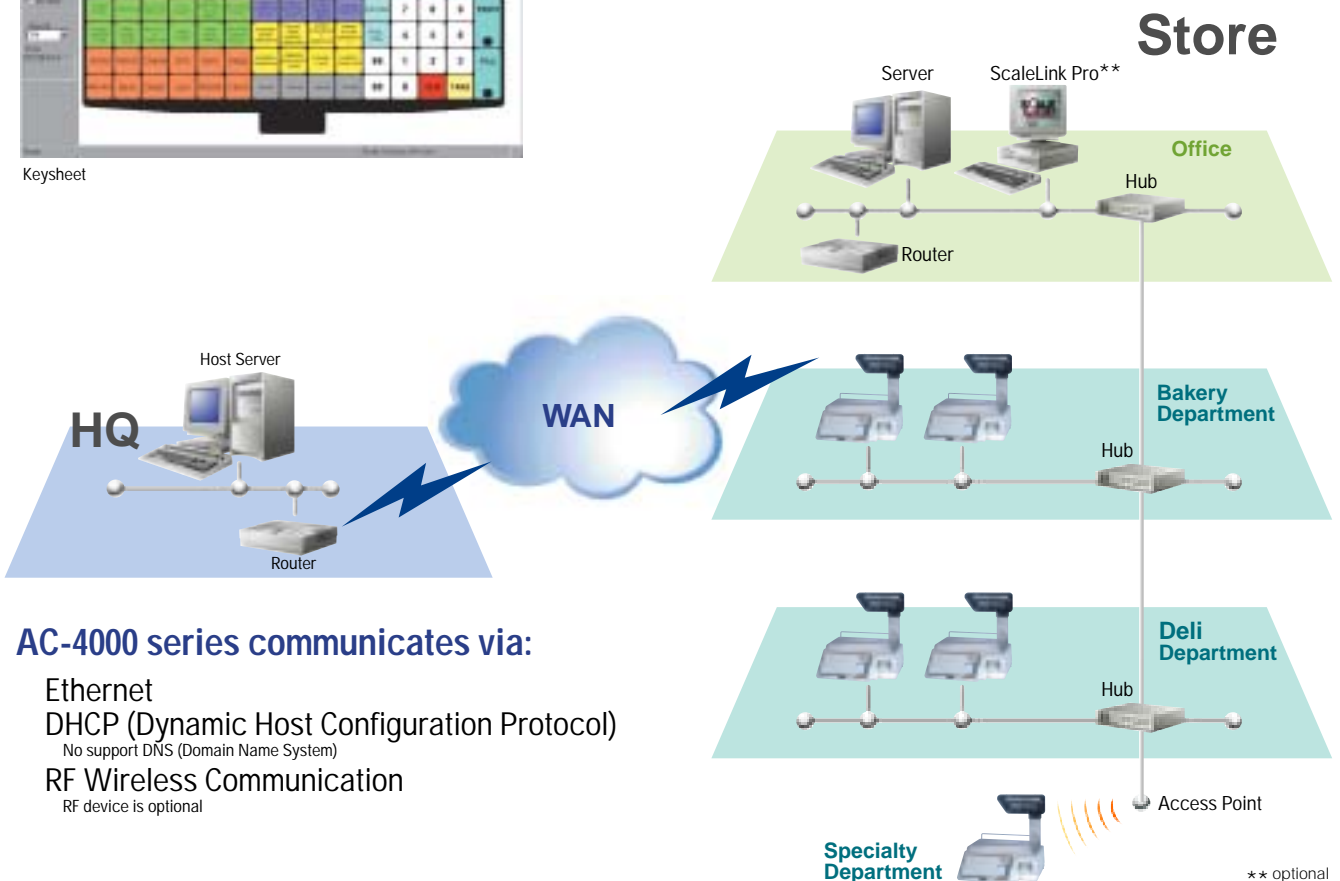

AC-4000 series communicates via:

- Ethernet
- DHCP (Dynamic Host Configuration Protocol)
No support DNS (Domain Name System)
- RF Wireless Communication
RF device is optional

** optional

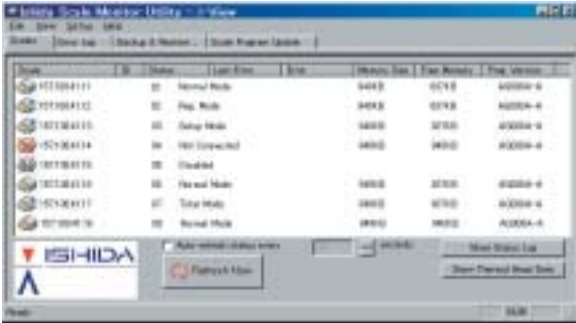

Scale status report screen gives you instant information

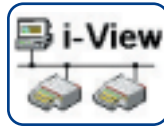

Remote diagnostics and data backup

Ishida's cutting-edge i-View software provides innovative remote scale diagnostics for your store. i-View provides secure operation and consistent service. Other features include:

- Scale status monitoring illustrates memory capacity, thermal head status, and more
- Error reports to assure system and data integrity
- Data and scale configuration back up
- Remote scale firmware upgrades for up-to-date scale operating system



Versatile label formatting

Use i-Label software to create eye-catching labels. This easy-to-use Windows based software allows you to create in-store labels locally or from a remote location like your store headquarters.

- Supports labels up to 240mm (9.5 inches) long
- Works with various labels and Ishida's patented label with perforated coupon to offer special in-store promotional opportunities
- Supports multiple logos for each PLU
- Various character sizes that can be freely italicized, underlined, reversed and bolded



i-Label makes creating dynamic labels easy



Specifications

Model	AC4000 / B	AC4000E	AC4000H	AC4000D
Capacity	6 kg / 2 g, 15 kg / 5 g (dual) 30 lb / 0.01 lb (dual)		15 kg / 5 g 30 lb / 0.01 lb	6 kg / 2 g, 15 kg / 5 g (dual) 30 lb / 0.01 lb (dual)
Accuracy	1 / 3000 (Dual interval)		1 / 3000 (Single range)	1 / 3000 (Dual interval)
Display	Fluorescent display (Upper) Dot matrix display (Lower) 256 x 16 dots	Fluorescent display (Upper)	Fluorescent display (Upper) Dot matrix display (Lower) 256 x 16 dots	Fluorescent display (Upper) Dot matrix display (Lower) 256 x 16 dots
	Type1 - tare: 4 digits, weight: 5 digits, unit price: 5 digits, total price: 6 digits Type2 - tare: weight: 5 digits, unit price: 8 digits, total price: 8 digits			
Label width	38 to 64 mm (1.5" - 2.5")			
Label printing width	60 mm (Up to 2.4")			
Label length	30 to 240 mm (1.2" - 9.5")			
Label backing paper width	67 mm (Up to 2.6")			
Printing speed	80 mm / sec. (3.2" / sec.)			
Label roll dimension	Inside diameter: 40 mm (1.6") Outside diameter: 100 mm (3.9")			Inside diameter: 40 mm (1.6") Outside diameter: 230 mm (9")
Interface	Ethernet, RS232C			
Keyboard	119 Key (186 presets)			
Memory capacity	Standard: 1 MB, Factory option: 2 MB			
Power supply	AC100 V / 120 V / 220 V / 240 V, 50/60 Hz			

Dimensions unit: mm (inch)

AC - 4000/B/E

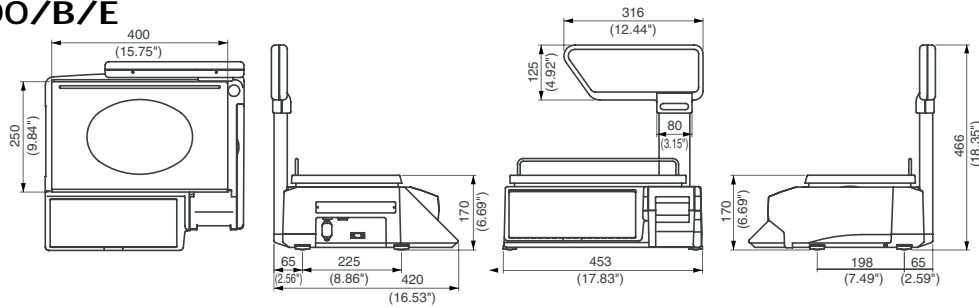

AC - 4000H

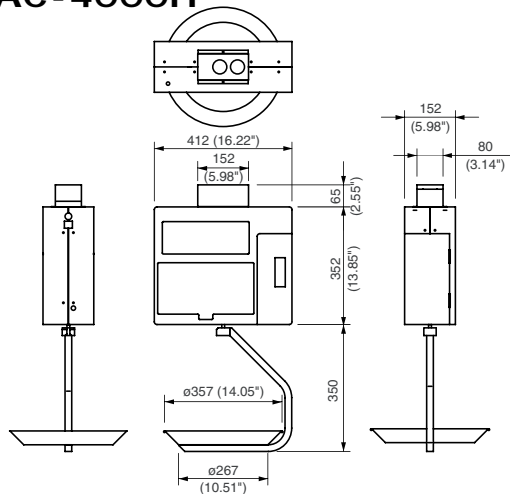

AC - 4000D

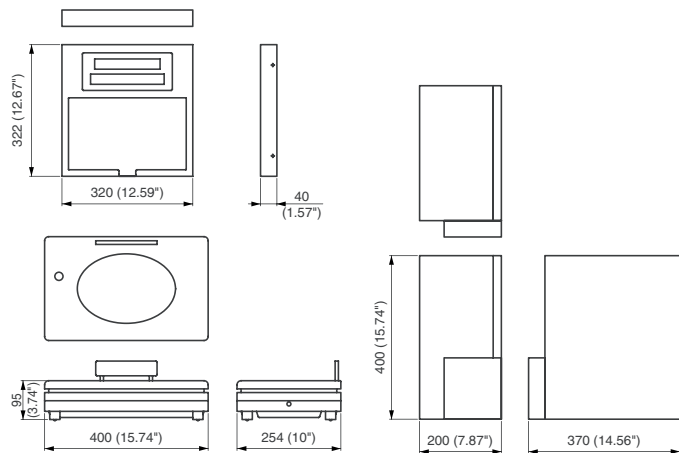

Specifications subject to change without notice

TOSHIBA

Toshiba TEC Canada Inc.

1-370 Britannia Rd E.,

Mississauga, ON L4Z 1X9

P: 905-890-8283

F: 905-890-0082

W: www.toshibateccanada.com